

PID Precision Ingredient Dosing

Process

The Van Aarsen Precision Ingredient Dosing system is designed as an integral part for a new or existing MID unit and suitable for very small quantities of ingredients which are suitable for a wide range of products used in the feed milling industry all with different bulk densities and flow characteristics.

The Van Aarsen ingredient dosing weigher range consists of 3 types:

- 1) Small Ingredient Dosing system, SID (max. 200 kg),
- 2) Micro Ingredient Dosing system, MID (max. 50 kg)
- 3) Precision Ingredient Dosing system, PID (max. 1 kg).



Benefits and features

High effectiveness MID with PID

- ▶ Large dosing and weighing range from 50 g - 50 kg
- ▶ Very accurate dosing with slide openings operating in sequence for fine and coarse dosing
- ▶ Short dosing time
- ▶ First-in first-out principle by silo design in combination with slides
- ▶ Two butterfly valves under the hopper
- ▶ Pneumatic beater on the weighing hopper
- ▶ Stirring device in the product hopper(s) (option)

Energy efficiency MID with PID

- ▶ Total installed power only 1.2 kW

Low maintenance costs MID with PID

- ▶ Due to the application of self-lubricating plastic frames around the moving parts, the machine operates smoothly with a minimum of wear
- ▶ Very low maintenance due to minimum of moving parts

Easy and safe operation MID with PID

- ▶ All moving parts are shielded for the safety of operating personnel
- ▶ Good accessibility to the weighing hopper

High feed quality MID with PID

- ▶ Parts in contact with product made of stainless steel
- ▶ Dosing by means of slides resulting in gentle product handling and no product damage
- ▶ Minimum contamination of product
- ▶ Built completely according to the latest regulations and standards for homogeneity, hygiene and safety

Flexibility MID with PID

- ▶ Wide dosing and weighing capacity range
- ▶ Vitamins, minerals and additives can be dosed with high accuracy for premix/concentrate production combined with larger dosings in the MID unit (dosing range 20 to 50 kg).
- ▶ The PID has a weighing and dosing range up to 1 kg and a dosing accuracy of 2 gram (weighing accuracy 1 gram).
- ▶ Silo extensions for new or existing dosing units by means of screw conveyor

High automation level MID with PID

- ▶ In case of a power breakdown, the dosing slides will automatically return to a closed position thus avoiding loss of product
- ▶ Integrated electrical control panel with reusable data
- ▶ Accurate monitoring of dosing slide position
- ▶ Operating in 'slave function' to the feedmill automation

Design MID with PID

- ▶ Compact design
- ▶ Durable construction
- ▶ Product hoppers integrated in design
- ▶ Silos on top of the dosing unit (optional)

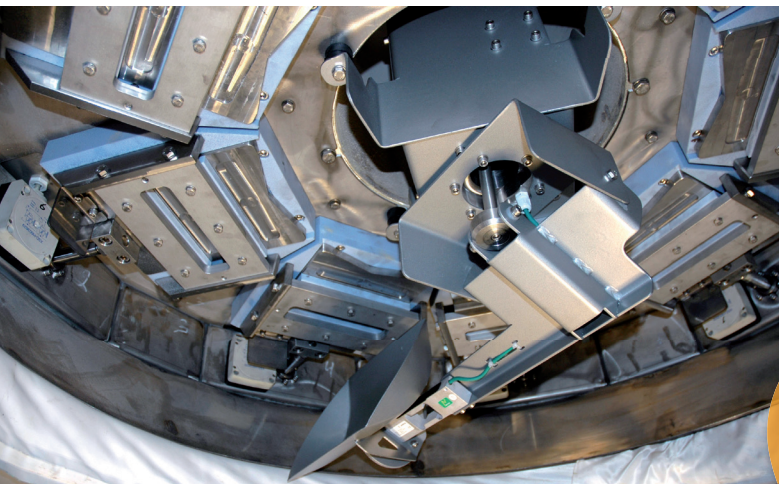

Datasheet

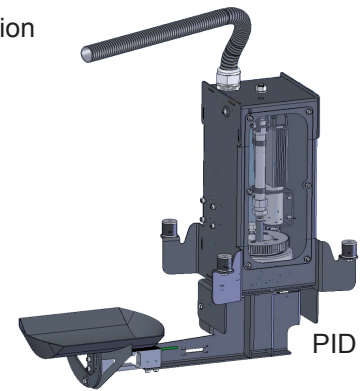
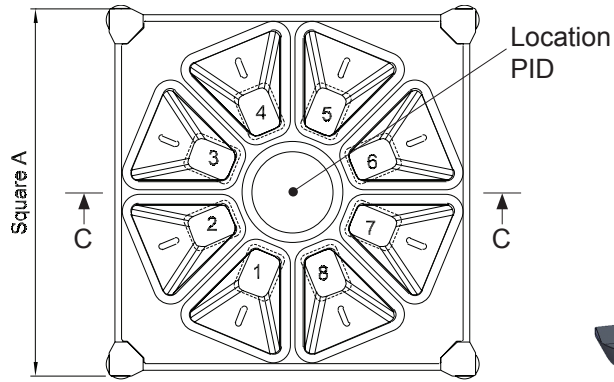

Detail C:

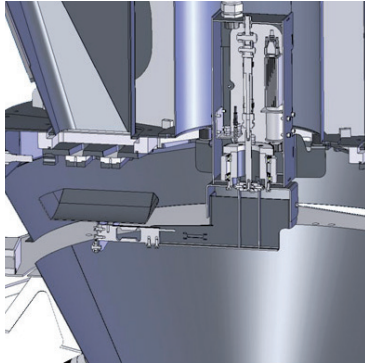

Position PID in MID

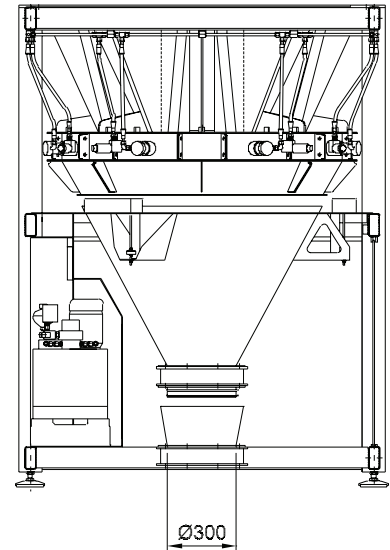
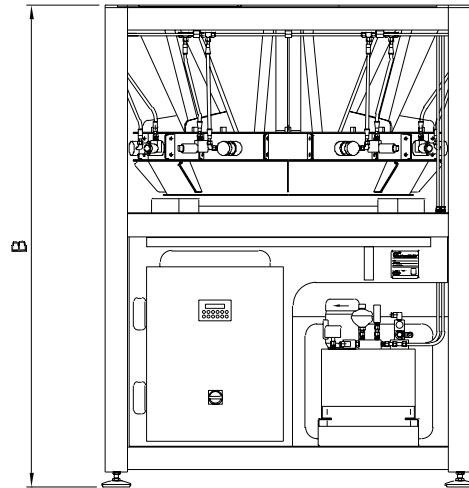

MID			
Dimensions	A=1600 mm, B=2100 mm		
Product silos	8		
Volume weighing hopper	0.2 m ³ (gross volume)		
Discharge outlet	300 mm		
Maximum batch weight	Smallest component:	Read out:	Weight accuracy: *
20 kg	500 g	10 g	10 g
50 kg	1000 g	20 g	17 g
Mechanical dosing accuracy **	5 g		
Number of load cells	3		
Load cell accuracy	0.02%		

PID			
Maximum batch weight	Smallest component:	Read out:	Weight accuracy: *
1000 g	50 g	1 g	1 g
Mechanical dosing accuracy **	2 g		
Number of load cells	1		
Load cell accuracy	0.02%		

* Weight accuracy (system) is the maximum deviation from the real value of the weight. This depends on the type of load cell used.
 ** Mechanical dosing accuracy describes the maximum feasible accuracy done by the dosing slides.